

<b>SPECIFICATION</b>		Specification No.	T-230430C11~C16			
		Drawing No.	T-230430C11	Revision		Page
Product Name	ZP-NM	Enactment Date	Apr. 07, 2026	Revision Date		
		Drawing Section	Sales Engineering Department			

### 1.General

This product is an SPD that protects equipment from abnormal voltages and currents applied to various communication lines and measurement lines. This product consists of an SPD plug and a jack. The SPD plug has a deterioration indication function, and the presence or absence of deterioration can be checked using a dedicated tester (ZPT1).

### 2.Service Condition

- 2.1 Install Location : Indoor
- 2.2 Ambient Temperature : -40°C~70°C
- 2.3 Relative Humidity : ≤96% (non-condensing)
- 2.4 Storage Temperature : -40°C~70°C
- 2.5 Storage Humidity : ≤96% (non-condensing)
- 2.6 Altitude : ≤2000m

### 3.Structure

#### 3.1 Appearance, Structure, and Dimensions

Table.1

Jack type	Model Number	Appearance
Screwless Terminals	ZP-NM	T-230430A11
Screw Terminals	ZP-NMJKN	T-230430A12

Mounting method: This SPD is standard for mounting on a DIN rail (35 mm wide).

Structure: This SPD has a structure that does not cause signal breakdown (including uninterruptible breakdown) even if the SPD plug is detached.

#### 3.2 Marking

The following items are indicated. For details, refer to the external drawing T-230430A11,A12.

Plug: (1) Product name (2) Manufacturer's name (3) Date of manufacture  
(4) Maximum continuous voltage  $U_c$  (5) UL Mark and UL characteristics  
(6) Two-dimensional code (Installation Instruction)

Jack: (1) Product name (2) Manufacturer's name (3) Date of manufacture (4) Terminal indication

<b>SPECIFICATION</b>		Specification No.	T-230430C11~C16			
		Drawing No.	T-230430C12	Revision		Page
Product Name	ZP-NM	Enactment Date	Apr. 07, 2026	Revision Date		
		Drawing Section	Sales Engineering Department			

### 3.3 Circuit Configuration

The circuit configuration of this SPD is shown in the figure below.

This SPD is directional. Incorrect connection may damage the SPD.

Connections should be made as shown in Figure 1 below.

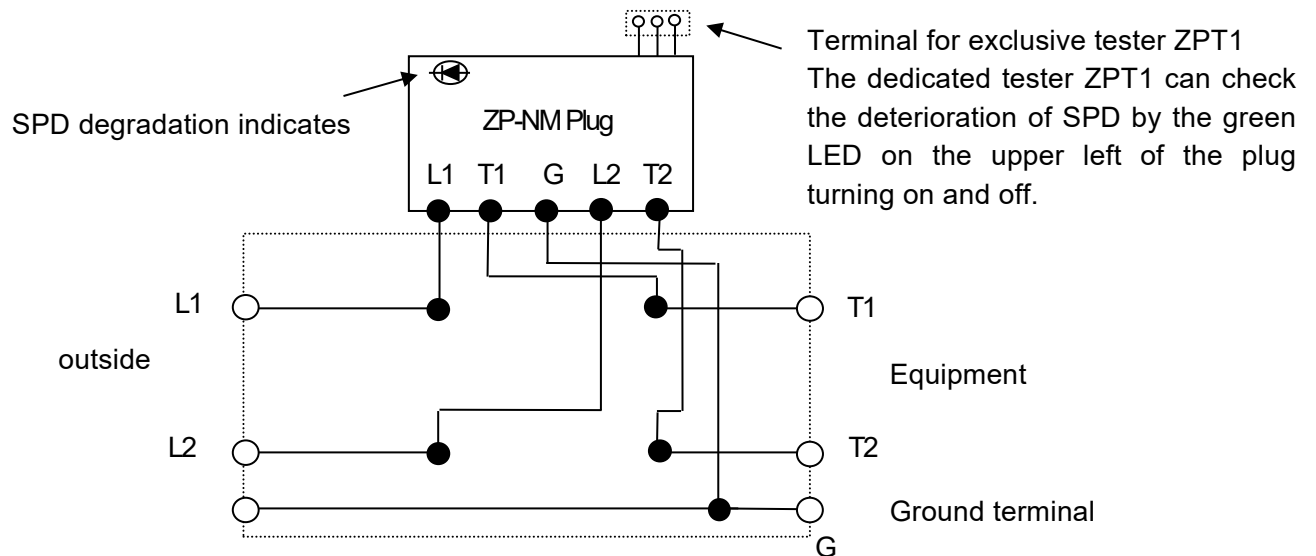

Figure 1: ZP-NM Circuit Configuration

### 4. Applicable Standards

The applicable standards of this product are shown in Table.2.

Table.2

Item	Standard
Applicable Standards	UL497B (File No.E140906)

<b>SPECIFICATION</b>		Specification No.	T-230430C11~C16			
		Drawing No.	T-230430C13	Revision		Page
Product Name	ZP-NM	Enactment Date	Apr. 07, 2026	Revision Date		
		Drawing Section	Sales Engineering Department			

## 5.Characteristics

### 5.1 Electrical and Protective Performance

SPD characteristics shown in Table.3.

Table.3

Item	Measuring conditions	Characteristics
	1. Maximum continuous voltage $U_c$	
2. DC Spark-over voltage $V_s$	100V/s	$\geq 180V$
3. Insulation resistance	150VDC	$\geq 10M\Omega$
4. Insertion loss	DC~1MHz	$\leq 1.0dB$
5. Voltage protection level $U_P$	1.2/50 $\mu$ s 4kV	L1-L2 50V
		T1,T2-G 1000V
6. Impulse durability	8/20 $\mu$ s 2kA	10 times (Category C2)
	10/350 $\mu$ s 0.5kA	2 times (Category D1)
7. Maximum discharge current $I_{max}$	8/20 $\mu$ s	10kA(5kA $\times$ 2)
	10/350 $\mu$ s	1kA(0.5kA $\times$ 2)
8. Impulse reset	48VDC 260mA	$\leq 30ms$
9. Rated Breakdown Voltage	100V/s	L-L:184-552V
		L-E:184-276V
10. AC durability	50Hz 0.5A 1s	5 times
11. Overload failure mode	-	Mode 1
12. Fault indicator	Inspection by special tester (ZPT1)	Normal:LED lighting
		Fault:LED off

Note 1) Temperature and humidity at the time of performance measurement are based on IEC 160-1963 (normal condition of test place): standard condition temperature  $20\pm 15^\circ C$  and standard condition humidity  $65\pm 20\%$ .

Note 2) Each item is tested in accordance with IEC 61643-21.

Note 3) Excluding resistance after trip operation

### 5.2 Determining when to replace this product

This product has a mechanism to disconnect the lightning protection device from the relevant line when an excessive abnormal current flows in.

By connecting the terminal of the dedicated tester ZPT1 to the terminal for the dedicated tester ZPT1 on the plug, the green LED will light up if it is normal. LED lights up when it is normal, and turns off when it is deteriorated.

If the green LED does not light up when inspected with the dedicated tester ZPT1, the plug part must be replaced.

<b>SPECIFICATION</b>		Specification No.	T-230430C11~C16			
		Drawing No.	T-230430C14	Revision		Page
Product Name	ZP-NM	Enactment Date	Apr. 07, 2026	Revision Date		
		Drawing Section	Sales Engineering Department			

## 6. Connection conditions

The cables that can be connected to the terminals mounted on this SPD are as follows.

### 6.1 Screwless terminals

Both stranded and single wires

AWG28~13(cross section:0.8~2.5mm<sup>2</sup>)

The recommended terminal treatment for cables to be connected to this SPD is as follows.

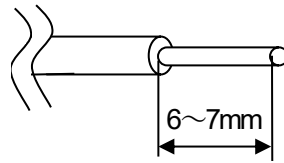

### 6.2 Screw terminals

Stranded wire

AWG24~14(cross section:0.2~2.63mm<sup>2</sup>)

Insulated crimp terminals compatible with M4, such as 0.3-4, 1.25-4, and 2-4

Tightening torque: 0.75N · m (7.6kgf · cm)

## 7. Inspection Condition

Electrical performance, visual and dimensional inspections are shown in Table 4.

Table.4

Item	Inspection type		How to check for Characteristics
	Process inspection	Product inspection	
1. DC Spark-over voltage Vs	Sampling	Sampling	According to Table.3
2. Insulation resistance	Sampling	Sampling	
3. Insertion loss	-	Type	
4. Voltage protection level U <sub>P</sub>	-	Type	
5. Impulse durability	-	Type	
6. Maximum discharge current I <sub>max</sub>	-	Type	
7. Impulse reset	-	Type	
8. Rated Breakdown Voltage	-	Type	
9. AC durability	-	Type	
10. Overload failure mode	-	Type	
11. LED lighting confirmation	Sampling	Sampling	According to Table.5
12. Low temperature test	-	Type	
13. High temperature test	-	Type	
14. Temperature cycle test	-	Type	
15. Vibration test	-	Type	
16. Appearance/Structure	Sampling	Sampling	According to T-230430A11, T-230430A12
17. Dimensions	Sampling	Sampling	

<b>SPECIFICATION</b>		Specification No.	T-230430C11~C16			
		Drawing No.	T-230430C15	Revision		Page
Product Name	ZP-NM	Enactment Date	Apr. 07, 2026	Revision Date		
		Drawing Section	Sales Engineering Department			

Note 1) In principle, sampling inspections shall be performed as a single sampling and sampling inspection in accordance with ISO2859 (Counting and sampling inspection procedures and sampling table), with AQL=2.5 based on the special inspection level S-3.

Note 2) Formal inspections are conducted on at least one unit for the first lot of a new production or when important materials or manufacturing methods are changed.

However, items whose performance can be confirmed with the same type of product may be omitted.

### 8.Environmental Test

The environmental performance of this SPD is shown in Table 5.

After each test, the DC discharge starting voltage, insulation resistance, series resistance, and voltage protection level performance shall be satisfied.

Table.5

Item	Test Condition	Test Time
1. Low temperature test	Ta=-40±3°C	1000h
2. High temperature test	Ta=+70±2°C	1000h
3. Temperature cycle test		30 cycles
4. Vibration test	JIS E 3014 Class 2, Class A Vibration frequency: 40 (Hz) Acceleration double amplitude: 19.6 m/s <sup>2</sup> (2G)	15min/3axis

### 9.Packing and Marking of Wrapping Box

We package in cardboard boxes in units of 10 pieces. The cardboard box will be labeled with the product name, manufacturer's name, and quantity.

### 10. Quality Assurance Period and Content of Assurance

The warranty period for this product is generally one year (\*) from the date of delivery. Failures that occur during this time will be repaired free of charge or replaced only with non-defective ones if the cause is clearly judged to be our responsibility. The warranty does not cover any damage or damage to the device caused by lightning. The cost of replacement is not covered by the warranty.

This product is shipped after strict in-house inspection. However, please contact the dealer or each branch office of purchase for any trouble caused by a malfunction or accident during transportation.

Purchased items are not covered by our warranty but are covered by the manufacturer's warranty.

\*If you wish to extend the warranty, we will discuss the warranty separately.

However, the warranty does not apply in the following cases:

<b>SPECIFICATION</b>		Specification No.	T-230430C11~C16			
		Drawing No.	T-230430C16	Revision		Page
Product Name	ZP-NM	Enactment Date	Apr. 07, 2026	Revision Date		
		Drawing Section	Sales Engineering Department			

- (1) If the product arises from use that is contrary to the conditions or precautions stated in the specifications or instruction manual, etc.
- (2) The effect of lightning strikes beyond product specifications, fire, earthquake, typhoon, eruption, flood, tsunami, salt damage, snow damage, freeze, abnormal temperature, abnormal vibration, Cases caused by other natural disasters.
- (3) When caused by changes in geology or topography,
- (4) Cases resulting from external factors such as fire, explosion, collision, corrosive gas, or contact with flying objects.
- (5) Cases arising from acts of a third party.
- (6) If the product is modified irrespective of our company, or improper handling such as moving, transporting or dropping the installation site, cases arising from secondary construction.
- (7) Cases caused by damage or improper construction of foundation or mounting pole. (outside our construction scope)
- (8) The failure or failure of the equipment connected to this product.
- (9) If it occurs without performing inspection and action for maintenance items recommended by us.

#### 11.Environmental correspondence

This product is applicable to EU RoHS Directive(\*) for regulated substances (10 substances: lead, mercury, cadmium, hexavalent chromium, PBB, PBDE, DEHP, BBP, DBP, DIBP), and does not include controlled substances that exceed regulatory limits.

\* European Parliament and Council Directive 2011/65/EU , (EU)2015/863