

1. Construction and dimensions

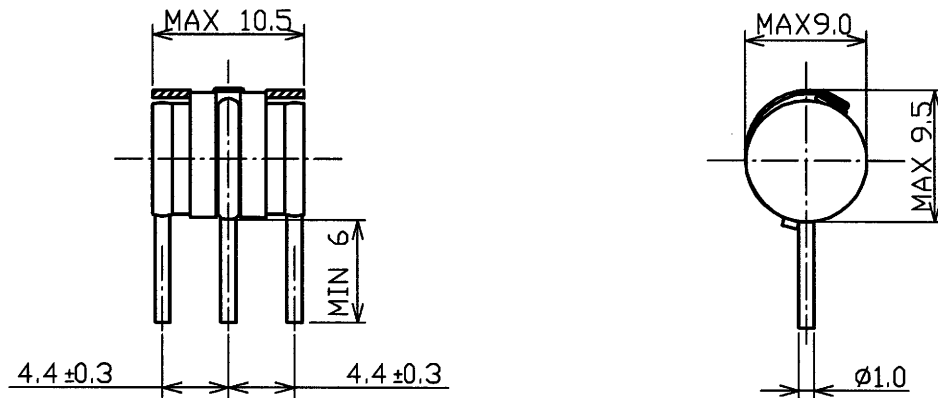

※Surface of Lead Wire : Tin plating

2. Marking

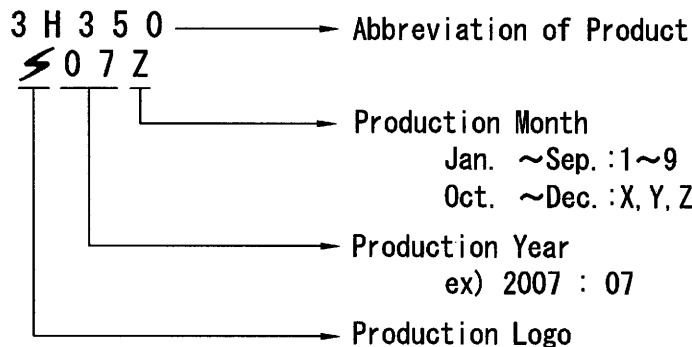

3. Electrical Characteristics

1. DC Spark-over Voltage	100V/s	280~420V
2. Impulse Spark-over Voltage	1kV/ μ s	<900V
3. Insulation Resistance	100V DC	>1,000M Ω
4. Capacitance	1MHz	<3.0pF
5. Holdover Voltage	ITU-T K. 12/Test 2 80V	<150ms
6. Arc Voltage		<20V
7. Impulse Transverse Voltage	1kV/ μ s	<200ns
8. Impulse Life	10/1000 μ s, 100A \times 2	300times
9. Impulse Discharge Current	8/20 μ s 10kA \times 2	+5, -5times
10. AC Discharge Current	50Hz 1sec, 10A \times 2	5times
11. Fail-safe Operation	AC 5A \times 2	<10sec

After Test of Item 8 and 9 and 10

1) DC Spark-over Voltage	100V/s	250~450V
2) Impulse Spark-over Voltage	1kV/ μ s	<1,000V
3) Insulation Resistance	100V DC	>100M Ω

DSN	S. E. D	Dec. 07. '07	UNIT	mm		TITLE	CERAMIC ARRESTER
DWG	M. Omata	Dec. 07. '07	SCALE	2/1		3YVH-350J1F5	
CHK	Y. Umano	Dec. 07. '07			DWG No.	T-070980C01	REV